

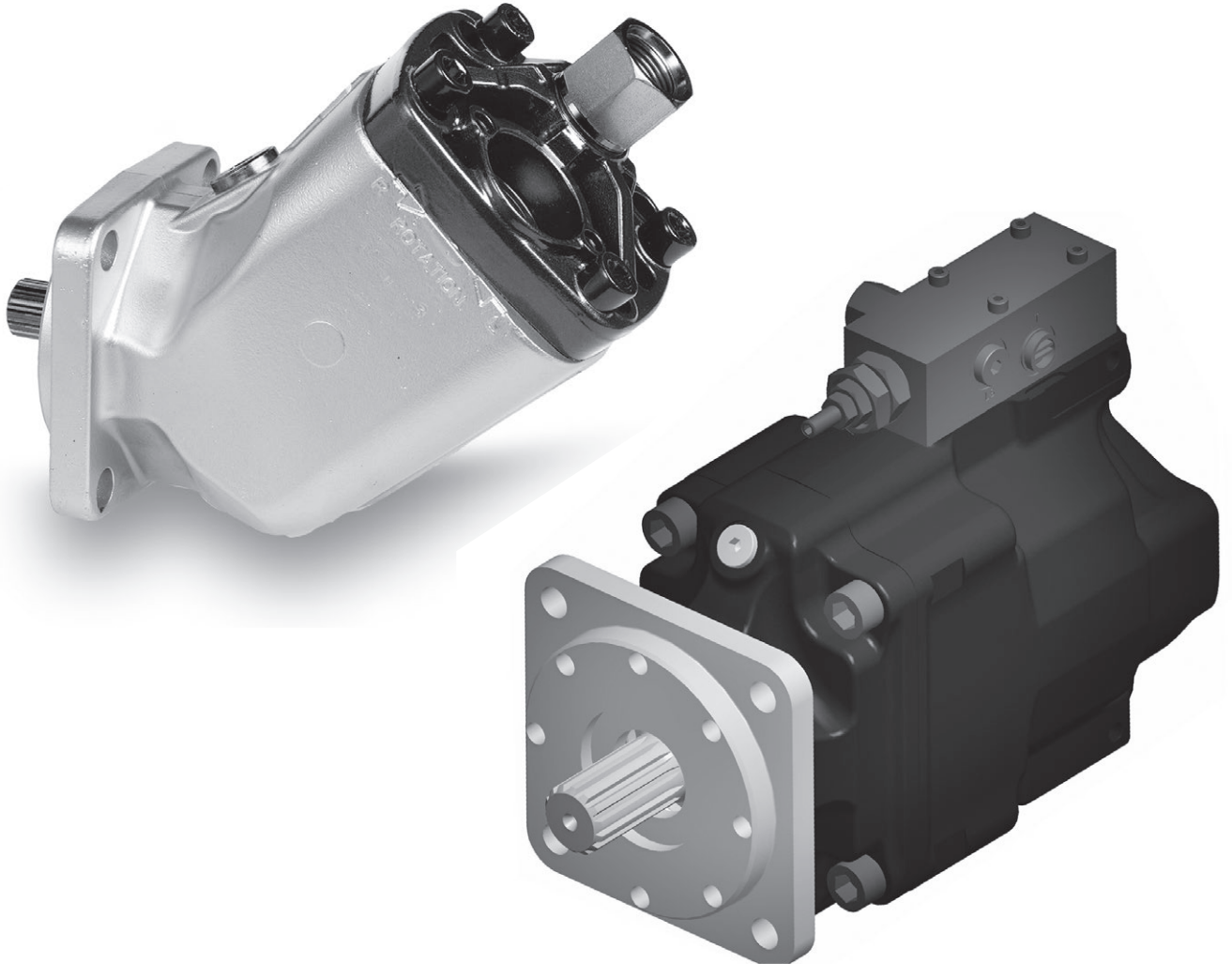

Visit our homepage for additional support [parker.com/pmde](http://parker.com/pmde)



# Truck Hydraulics

Series F1 and VP1, SAE versions  
Fixed and Variable Displacement Pumps  
and Accessories



ENGINEERING YOUR SUCCESS.

**Conversion factors**

1 kg .....	2.20 lb
1 N.....	0.225 lbf
1 Nm.....	0.738 lbf ft
1 bar .....	14.5 psi
1 l .....	0.264 US gallon
1 cm <sup>3</sup> .....	0.061 cu in
1 mm .....	0.039 in
$\frac{9}{5} \text{ }^{\circ}\text{C} + 32$ .....	$1^{\circ}\text{F}$
1 kW.....	1.34 hp

---

<b>Content</b>	<b>Page</b>
F1 Pump	
Fixed Displacement – Axial Piston Pump, SAE version.....	4 – 7
VP1 Pump	
Variable Displacement – Axial Piston Pump. SAE version.....	8 – 14
Pump and line selection .....	15 – 17
Suction fittings and fitting kits .....	18
Installation and start up, F1 and VP1 .....	19 – 21

## F1 Pump

### F1-SAE



<b>Contents</b> .....	<b>Page</b>
General Information .....	5
F1 Pump SAE.....	5
Specifications.....	6
Pump cross section.....	6
Installation Dimensions, F1-25, -41, -51 and -61 (SAE) .....	7
Ordering code (SAE) .....	7
Port size .....	7
Standard SAE versions .....	7
Pump and Line selection.....	15
Suction fittings.....	18
Installation and start up .....	19

## F1 Pump SAE

Series F1 is a further development of our well known 'truck pump', the F1. The F1 offers many additional values for operators of cargo cranes, hook loaders, skip loaders, forest cranes, concrete mixers and similar truck applications.

Series F1 is a very efficient and straight forward pump design with unsurpassed reliability.

Its small envelope size gives a simple and inexpensive installation.

### Features:

- Laminated piston rings – low leakage
- Positive synchronisation with timing gear
- Operating pressure up to 350 bar (5076 psi)
- Installation above the reservoir level possible
- Tolerates low temperatures and high temperature shocks
- Shaft end and mounting flange meet the standard SAE-B
- 4 sizes -25 / -41 / -51 / -61 cm<sup>3</sup>/rev  
1.56 / 2.50 / 3.12 / 3.63 cu in/rev

### ... thanks to:

- 45° bent-axis angle
- Optimal inlet port geometry in the end cap
- Single housing design
- Spherical pistons – high speeds
- Laminated piston rings – low leakage
- Positive synchronisation with timing gear
- Installation above the reservoir level possible
- Tolerates low temperatures and high temperature shocks
- Shaft end and mounting flange meet the SAE standard for all sizes

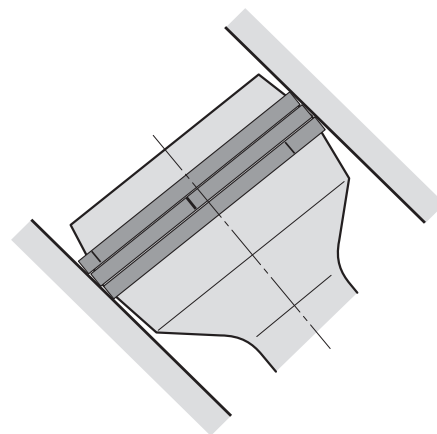

*F1 piston with laminated piston ring.*

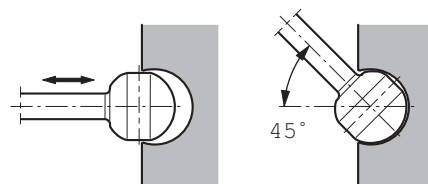

*F1 piston-to-shaft locking.*

## Specifications

Size F1 -	25	41	51	61
<b>Displacement</b> [cm <sup>3</sup> /rev]	25.6	40.9	51.1	59.5
	[cu in/rev]	1.56	2.50	3.12
<b>Max flow</b> <sup>1)</sup> [l/min]	67	98	112	131
	[gpm]	17.7	25.9	29.6
<b>Max operating pressure</b> [bar]	350	350	350	350
	[psi]	5000	5000	5000
<b>Mass moment of inertia J</b> [kgm <sup>2</sup> ]	0.00274	0.00266	0.00261	0.00257
<b>Shaft speed</b> [rpm]				
- short circuited pump (low press.)	2700	2700	2700	2700
- max speed at 350 bar <sup>2)</sup> /5000 psi <sup>2)</sup>	2600	2400	2200	2200
<b>Torque</b> <sup>1)</sup>				
at 350 bar [Nm]	142	227	284	331
at 5000 psi [lbf ft]	105	168	210	244
<b>Input power</b>				
[kW]	39	57	66	76
[hp]	52	76	88	102
<b>Weight</b> [kg]	8.5	8.5	8.5	8.5
	[lbs]	18.7	18.7	18.7

<sup>1)</sup> Theoretical values

<sup>2)</sup> Valid at an inlet pressure of 1.0 bar/15 psi (abs.) when operating on mineral oil at a viscosity of 30 mm<sup>2</sup>/s (cSt)/150 SUS.

**NOTE:** For noise level information, contact Parker Hannifin.

## Pump cross section

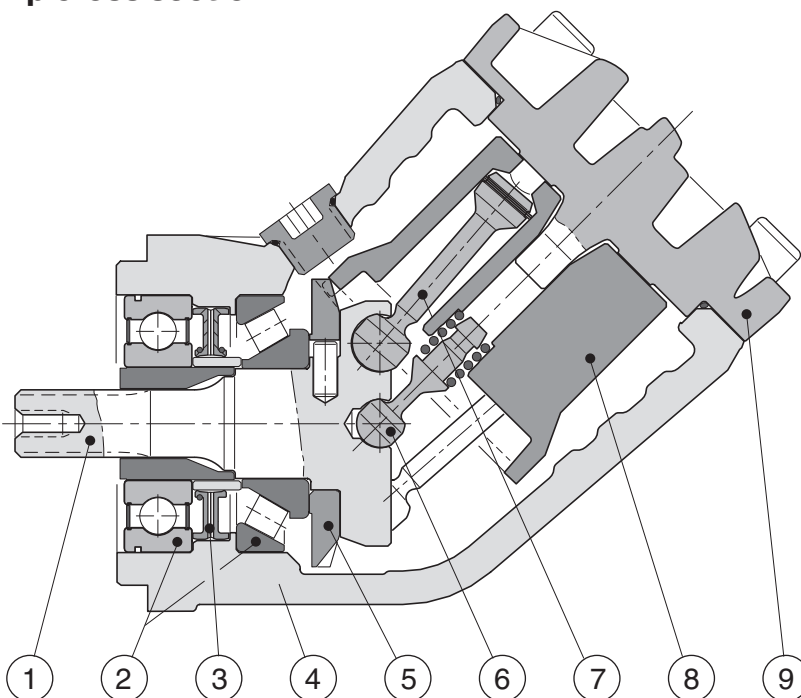

1. Input shaft
2. Bearings
3. Shaft seal
4. Housing
5. Timing gear
6. Barrel support
7. Piston with piston ring
8. Cylinder barrel
9. End cap

**Installation dimensions, F1-25, -41, -51 and -61 (SAE)**

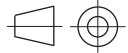

Dimensions in mm [inches]

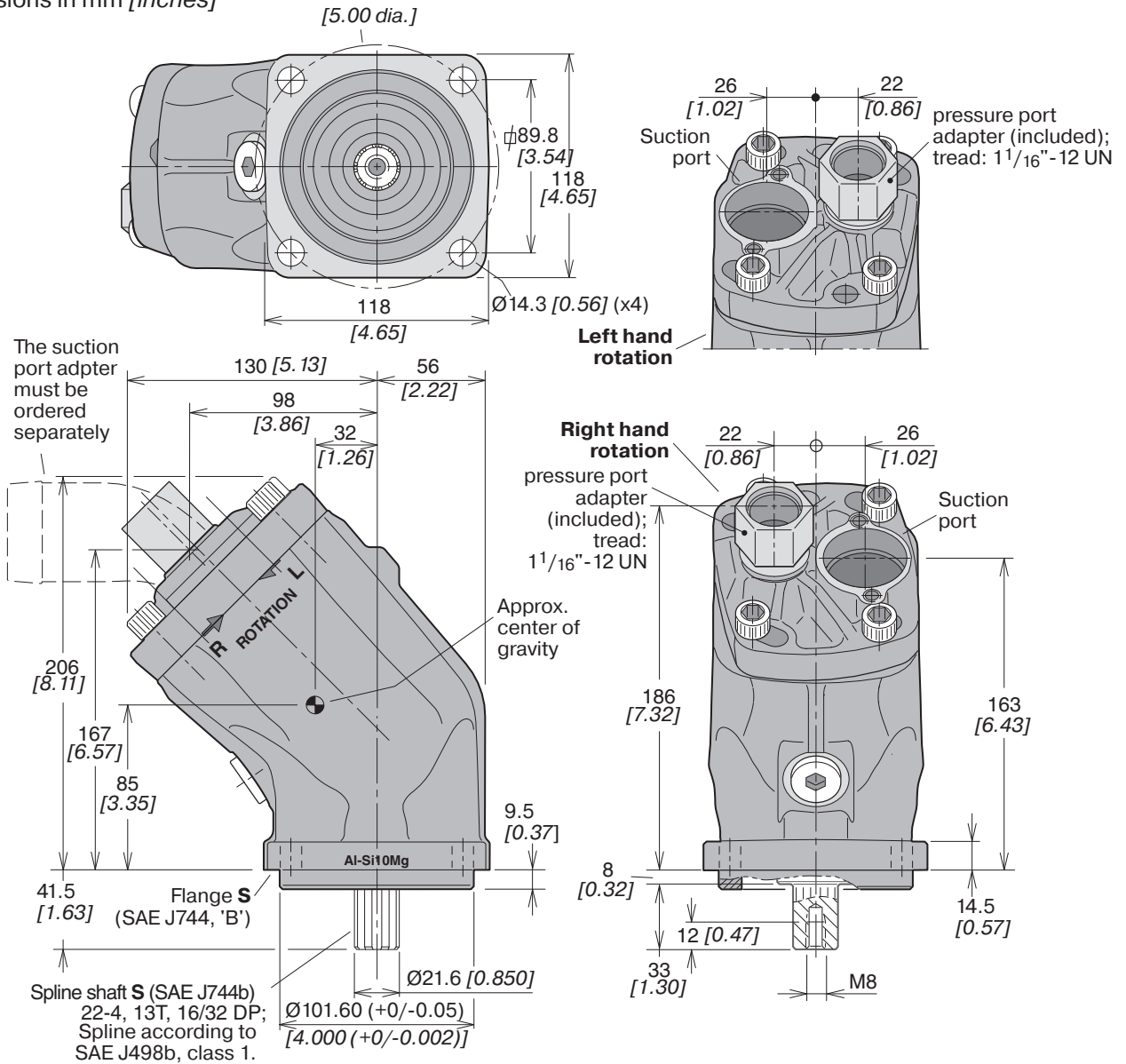

**Ordering code (SAE)**

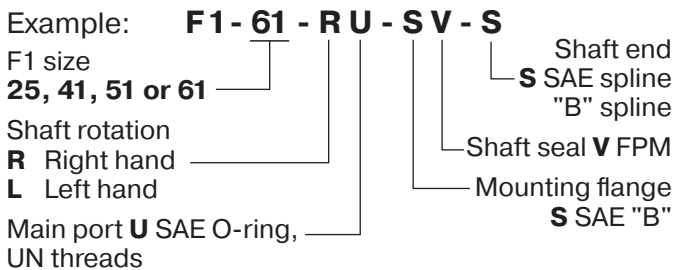

**NOTE:** The pump **does not** include a suction fitting; it must be ordered separately. See page 18

**Standard SAE versions Port size**

Designation	Ordering no.
F1-25-RU	378 1424
F1-25-LU	378 1425
F1-41-RU	378 1440
F1-41-LU	378 1441
F1-51-RU	378 1450
F1-51-LU	378 1451
F1-61-RU	378 1460
F1-61-LU	378 1461

F1 size	Pressure port <sup>1)</sup>
-25	1 1/16" - 12 UN
-41	1 1/16" - 12 UN
-51	1 1/16" - 12 UN
-61	1 1/16" - 12 UN

<sup>1)</sup> BSP-to-SAE adapter (included)

**VP1 Pump**

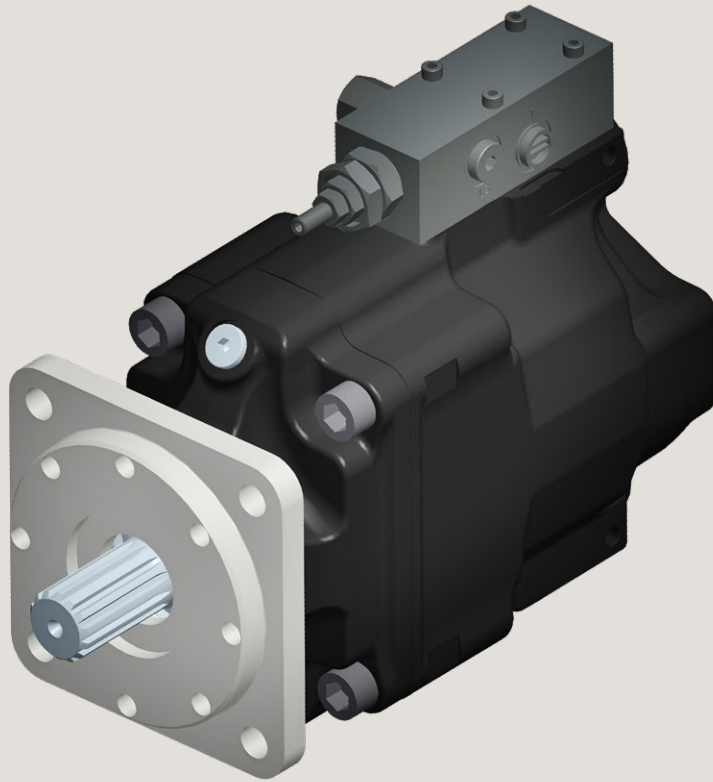

<b>Contents.....</b>	<b>Page</b>
General Information .....	9
Specifications.....	10
VP1-095/- 110/- 130 cross section .....	10
LS control (for VP1-095/- 110/- 130) .....	11
Installation Dimensions (for VP1-095/- 110/- 130) .....	12
Ordering information .....	13
VP1 in load sensing systems .....	13
Systems comparison.....	13
Standard model numbers .....	13
LS load sensing control function.....	14
LS control adjustments .....	14
Hydraulic schematic for VP1-095/- 110/- 130 .....	14
Pump and Line selection.....	15
Suction fittings.....	18
Installation and start up .....	19



## VP1 Pump SAE

The VP1 is a variable displacement pump for truck applications. It can be close-coupled to a gearbox PTO (power take-off) or to a coupling independent PTO (e.g. an engine PTO).

An application that makes full use of all the features of the VP1 is truck cranes with a load sensing system. The complex systems of refuse collection vehicles and sewage trucks as well as various combinations of tippers, cranes, snow ploughs, and salt/sand spreaders can also be greatly simplified and optimised with the VP1 pump.

The VP1 provides the hydraulic system with the correct amount of fluid at precisely the right moment, effectively reducing energy consumption and heat generation. This means a smoother and quieter hydraulic system with much reduced impact on the environment.

The VP1 is highly efficient and extremely light. It is reliable, economical and easy to install.

The 3 sizes, VP1-095, -110 and -130 have small installation dimensions.

## Design

### Large angle – compact design

The pump design permits a large angle, 20°, between piston and slipper shoe/swashplate, providing compactness and small outer dimensions.

### Long life

The VP1 is designed for trucks with hydraulic load sensing systems. It is sturdy, yet simple, with few moving parts. The result is a reliable pump with long service life.

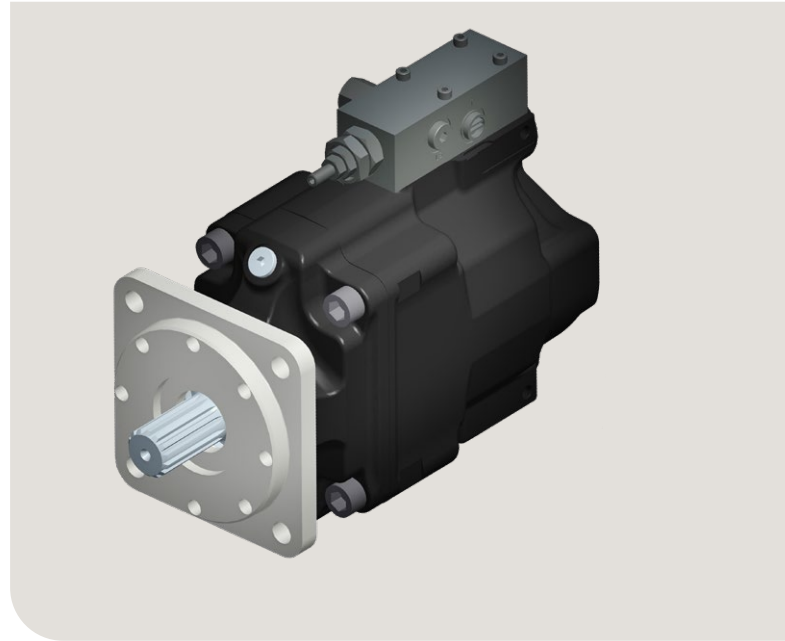

*The VP1 is suitable for all load sensing systems, regardless of make.*

## Features

- Variable displacement
- Low noise level
- High power-to-weight ratio
- Compact and light
- Highly efficient
- Sturdy design
- Withstands low temperatures

## Retainer plate

The retainer plate (refer to the cut-away illustration in next page) is of a heavy duty design which makes the pump withstand high shaft speeds and fast speed changes. (e.g. engine PTO).

## Specifications

Size VP1 -	095	110	130
<b>Displacement</b> [cm <sup>3</sup> /rev]	95	110	128
[cu in/rev]	5.80	6.71	7.81
<b>Max operating pressure</b>			
continuous [bar]/[psi]	400 / 5800	400 / 5800	350 / 5075
intermittent <sup>1)</sup> [bar]/[psi]	420 / 6090	420 / 6090	370 / 5365
<b>Mass moment of inertia J</b> [kgm <sup>2</sup> ]	0.00681	0.00690	0.00690
<b>Selfpriming speed</b> <sup>2)</sup> [rpm]			
2" suction line, max	1250	1100	900
2 <sup>1</sup> / <sub>2</sub> " suction line, max	1750	1500	1300
3" suction line, max	2200	2100	1900
<b>Min Speed</b> [rpm]	500	500	500
<b>Max Speed unloaded</b> [rpm]			
(in bypass mode, no flow)	3000	3000	3000
<b>Control type</b>	LS		
<b>Shaft end spline</b>	Spline SAE C 14T 12/24 DP		
<b>Mounting flange</b>	SAE C 4 bolt flange		
<b>Weight (with control)</b> [kg]	27		
[lbs]	59.5		

<sup>1)</sup> Max 6 seconds in any one minute.

<sup>2)</sup> At an inlet pressure of 1.0 bar (abs.) with mineral oil at a viscosity of 30 mm<sup>2</sup>/s (cSt).

## VP1-095/-110/-130 cross section

1. Shaft seal
2. Roller bearing
3. 'Upper' purge plug
4. Bearing shell
5. Setting screw (pressure relief valve)
6. Setting bushing (standby pressure)
7. Control
8. Piston with piston shoe
9. 'Upper' setting piston (control pressure)
10. Needle bearing
11. Shaft
12. Drain hole, shaft seals
13. 'Lower' purge plug
14. Bearing housing
15. Swash plate
16. Retainer plate
17. 'Lower' setting piston (pump pressure)
18. Cylinder barrel
19. Valve plate
20. Barrel housing
21. SAE C 4 bolt flange

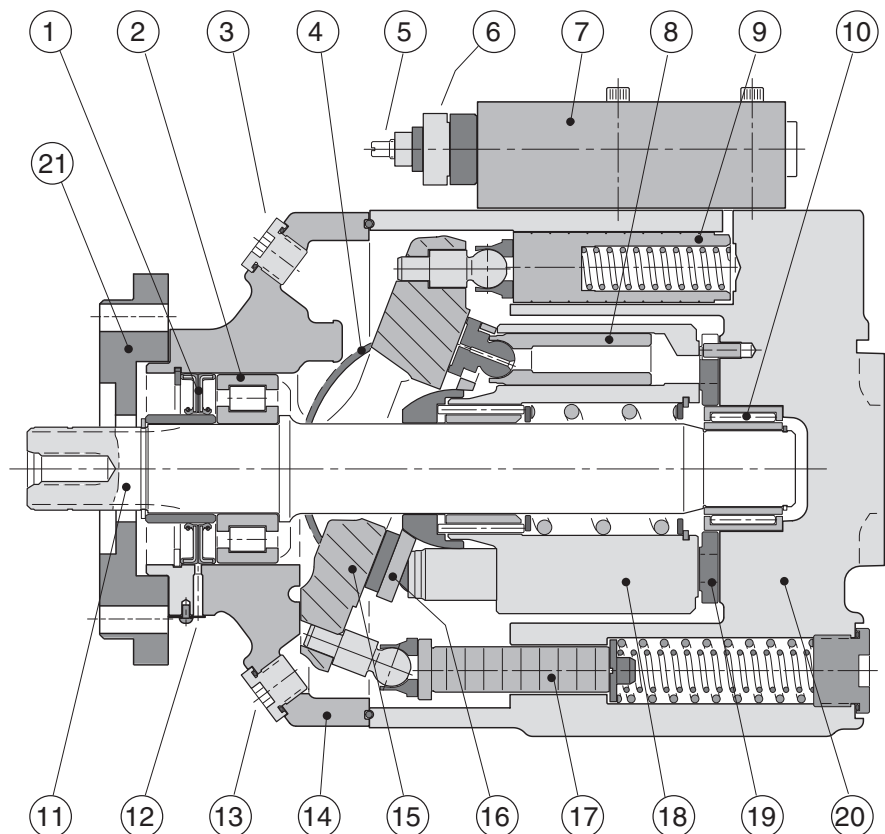

● **LS control** (for VP1-095/- 110/- 130)

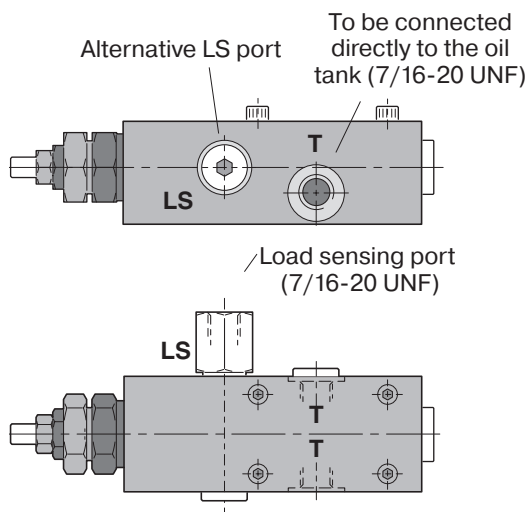

LS control ports.

**NOTE:** Always run a function, after adjusting the standby pressure or the max pressure setting, before you read the value.

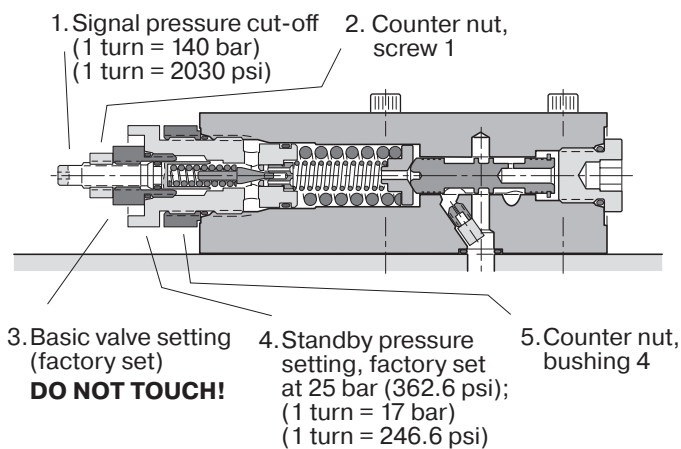

LS control cross section.

Item	Wrench / dimension
1	Hex Head Wrench / 4 mm
2	Wrench / 13 mm
3	<b>DO NOT TOUCH</b>
4	Wrench / 27 mm
5	Wrench / 27 mm

**VP1-095/-110/-130**

Dimensions in mm [inches]

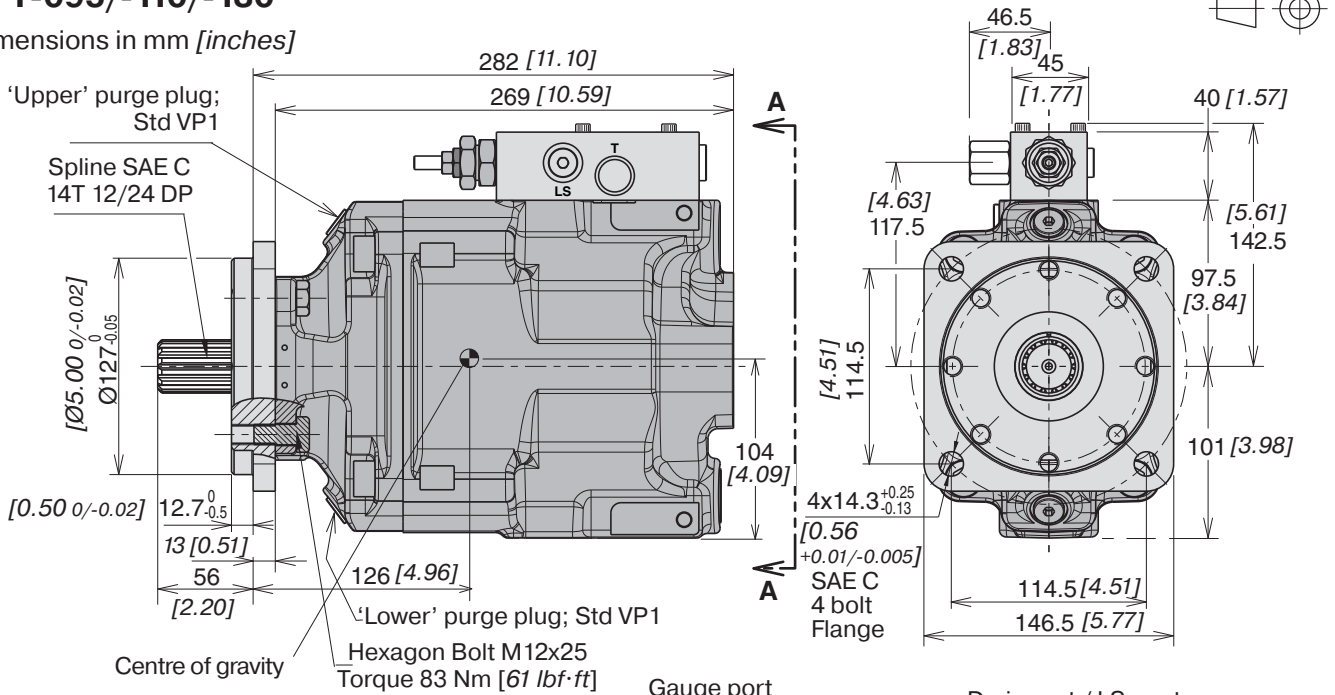

**NOTE:**  
The pump **does not** include a suction fitting; it must be ordered separately. See page 18.

**IMPORTANT!**  
The control is **not** drained through the pump case; an external drain line must be installed from control port T and, directly, to the oil tank.

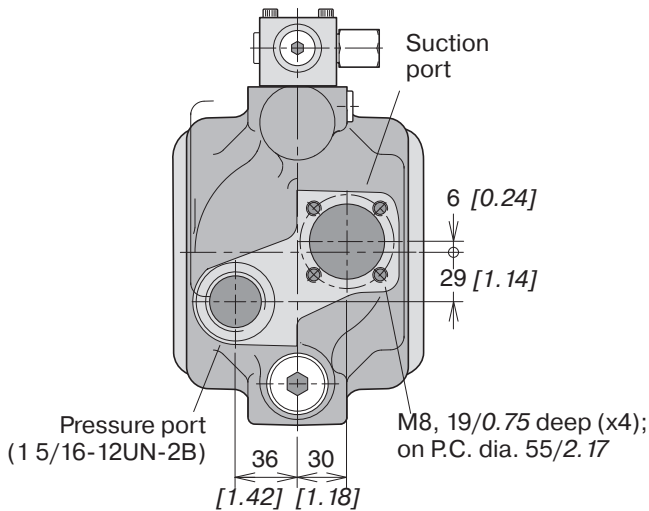
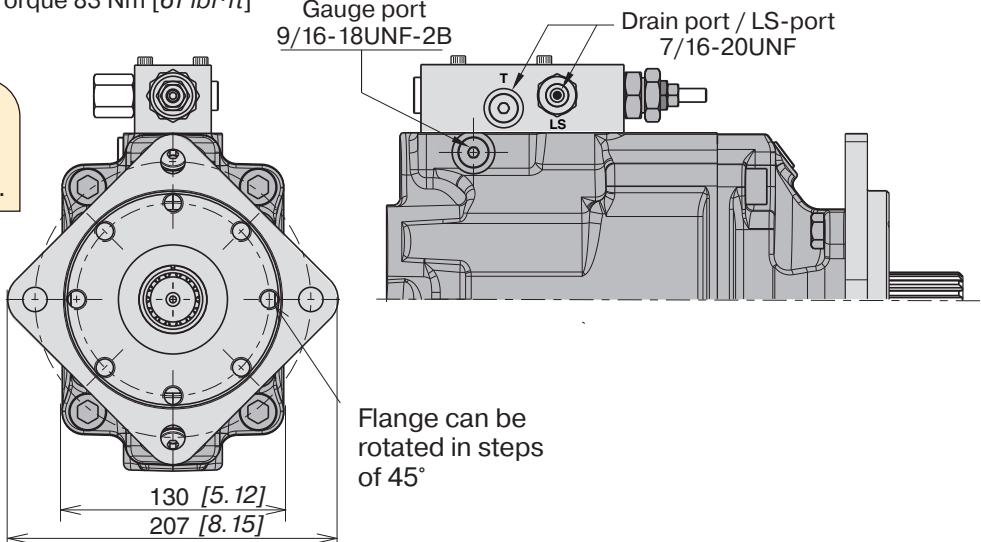

**View A-A**  
Left hand rotating pump

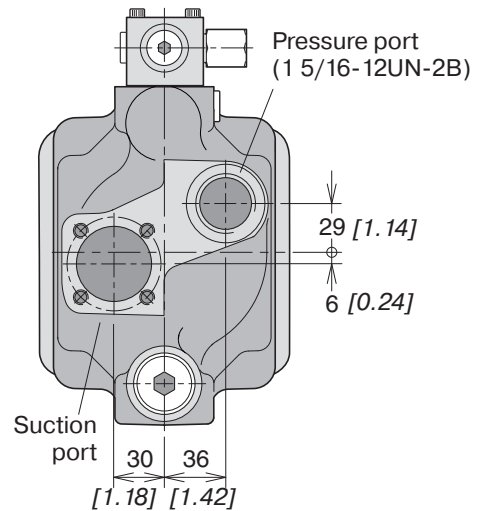

**View A-A**  
Right hand rotating pump

### Ordering information

Example: **VP1 - 095 - RU - SV - S - 102**

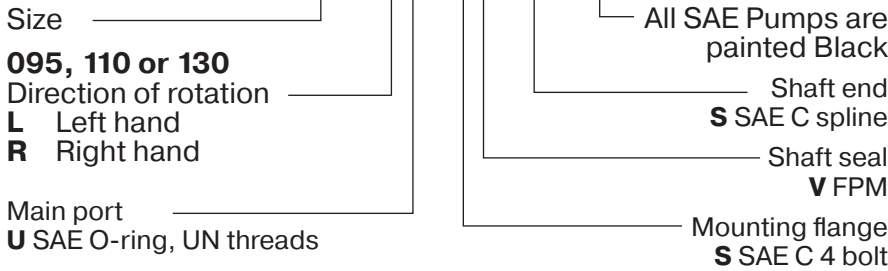

### Standard model numbers

Designation	Ordering no.
VP1-095-RU	378 4095
VP1-095-LU	378 4096
VP1-110-RU	378 4093
VP1-110-LU	378 4094
VP1-130-RU	378 4091
VP1-130-LU	378 4092

**NOTE:** The VP1 is uni-directional. Consequently, the desired direction of rotation must be stated *when ordering*.

### VP1 in load sensing systems

When installed in a load sensing system, the VP1 supplies the correct amount of flow required by the various work functions currently engaged.

This means that energy consumption and heat generation are minimised and much reduced in comparison with a fixed displacement pump used in the same system.

Diagram 1 shows the required power (flow times pressure) in a constant flow system with a fixed displacement pump.

Diagram 2 shows the sharply reduced power requirement in a load sensing system with a variable displacement pump such as the VP1.

In both cases the pump pressure is slightly higher than what is required by the heaviest load ('Load 2') but the VP1, because of the much smaller flow being delivered, needs only the power indicated by the shaded area 'Load power'.

In a constant flow system, on the other hand, excess fluid is shunted to tank and the corresponding power, 'Wasted power' (shown in diagram 1), is a heat loss.

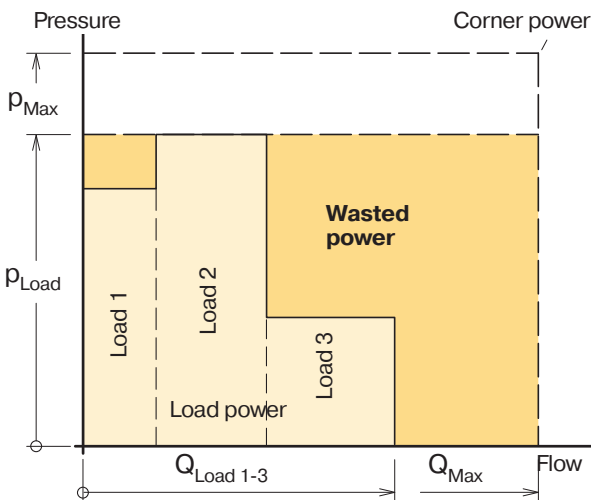

Diagram 1. Constant flow system with a fixed displacement pump.

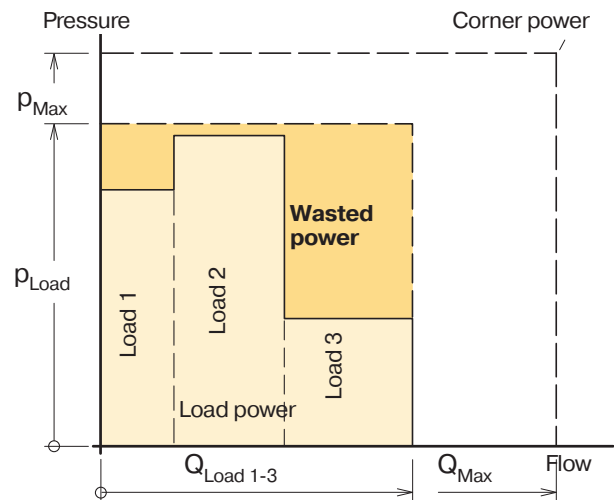

Diagram 2. Constant flow system with a variable displacement pump (e.g. VP1).

### Systems comparison

System	Constant flow	Load-sensing
Pump	Fixed displ.	VP1 variable displ.
Pump adjustments	Pressure only	Pressure and flow
Load *	Some influence	Some influence
Energy consumption	High	Low
Heat generation	High	Low

\* Simultaneous operation of loads with non-equal flows and pressures; refer to the above diagrams.

### LS load sensing control function

Refer to corresponding hydraulic schematic below.

A selected 'opening' of the directional control valve spool corresponds to a certain flow to the work function. This flow, in turn, creates a pressure differential over the spool and, consequently, also a  $\Delta p$  between the pump outlet and the LS port.

When the differential pressure decreases (e.g. the directional valve is 'opened' further) the  $\Delta p$  also decreases and the LS valve spool moves to the left. The pressure to the setting pistons then decreases and the pump displacement increases.

The increase in pump displacement stops when the  $\Delta p$  finally reaches the setting (e.g. 25 bar) and the forces acting on the valve spool are equal.

If there is no LS signal pressure (e.g. when the directional valve is in the neutral, no-flow position) the pump only delivers sufficient flow to maintain the standby pressure as determined by the  $\Delta p$  setting.

### LS control adjustments

#### Pressure limiter

Pump size	Factory setting [bar/psi]	Max pressure intermittent [bar/psi]
VP1- 095/110/130	350 / 5075	420 / 6090*

\* **Note:** Max allowed pressure for size VP1-130 is 370 bar

Pump size	Factory setting [bar/psi]	Min pressure [bar/psi]	Max pressure [bar/psi]
VP1- 095/110/130	25 / 363	15 / 218	40 / 580

#### LS load sensing valve

The factory setting, and the standard orifice sizes shown in the corresponding schematic below, will usually provide an acceptable directional valve characteristic as well as system stability.

For additional information, contact Parker Hannifin.

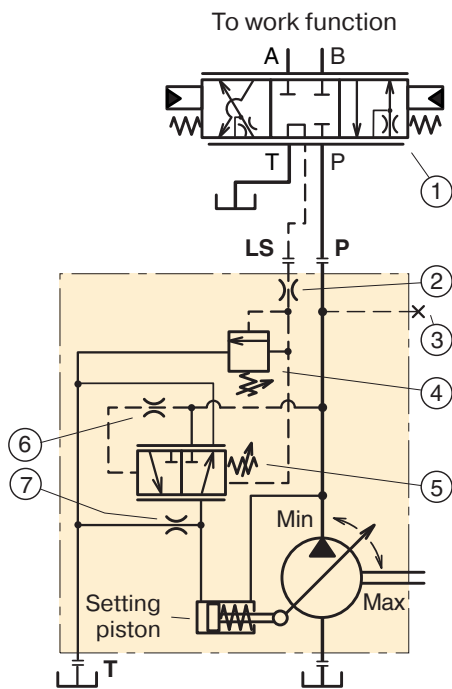

1. Directional, load sensing control valve
2. Load signal orifice (1.0 mm)
3. Gauge port
4. Signal pressure limiter adjustment
5. Standby ( $\Delta p$ ) pressure adjustment
6. System pressure dampening orifice (fixed)
7. Bleed-off nozzle (1.2 mm)

Hydraulic schematic for VP1-095/-110/-130

## Pump selection

### F1

The following table shows pump flow at selected PTO gear ratios and engine rpm's.

PTO gear ratio	Engine speed [rpm]	Pump flow [l/min / gpm]			
		F1-25	F1-41	F1-51	F1-61
1:0.8	800	16 / 4.23	26 / 6.87	33 / 8.72	38 / 10.04
	900	18 / 4.76	29 / 7.66	37 / 9.77	43 / 11.36
	1000	20 / 5.28	33 / 8.72	41 / 10.83	48 / 12.68
	1100	23 / 6.08	36 / 9.51	45 / 11.89	52 / 13.74
	1200	25 / 6.60	39 / 10.30	49 / 12.94	57 / 15.06
1:1.0	800	20 / 5.28	33 / 8.72	41 / 10.83	48 / 12.68
	900	23 / 6.08	37 / 9.77	46 / 12.15	54 / 14.27
	1000	26 / 6.87	41 / 10.83	51 / 13.47	60 / 15.85
	1100	28 / 7.40	45 / 11.89	56 / 14.79	65 / 17.17
	1200	31 / 8.19	49 / 12.94	61 / 16.11	71 / 18.76
1.1.25	800	26 / 6.87	41 / 10.83	51 / 13.47	60 / 15.85
	900	29 / 7.66	46 / 12.15	57 / 15.06	67 / 17.70
	1000	32 / 8.45	51 / 13.47	64 / 16.91	74 / 19.55
	1100	35 / 9.25	56 / 14.79	70 / 18.49	82 / 21.66
	1200	38 / 10.04	61 / 16.11	77 / 20.34	89 / 23.51
1:1.5	800	31 / 8.19	49 / 12.94	61 / 16.11	71 / 18.76
	900	35 / 9.25	55 / 14.53	69 / 18.23	80 / 21.13
	1000	38 / 10.04	61 / 16.11	77 / 20.34	90 / 23.78
	1100	42 / 11.10	67 / 17.70	84 / 22.19	98 / 25.89
	1200	46 / 12.15	74 / 19.55	92 / 24.30	107 / 28.27

## Flow and torque formulas

(no regard to efficiency)

$$\text{Flow: } Q = \frac{D \times n}{1000} \text{ [l/min]}$$

where: D is pump displacement [cm<sup>3</sup>/rev]  
 n is shaft speed [rpm]

$$\text{Torque: } M = \frac{D \times p}{63} \text{ [Nm]}$$

where: D is pump displacement [cm<sup>3</sup>/rev]  
 p is utilised pressure [bar]

### NOTE:

- Make sure max torque and bending moment (due to the weight of the pump) of the utilised PTO are not exceeded. (The approx. center of gravity of the various pump sizes are shown in the installation drawings).
- Make sure max allowed output torque from the PTO is not exceeded.
- Contact Parker Hannifin if the inlet (suction) pressure is believed to be less than 1.0 bar (absolute); insufficient inlet pressure can cause noise and pump damage because of cavitation.

A suitable pump size for a truck application can be selected as follows:

**Operating conditions**

As an example, a cargo crane specifies:

- Flow: 60 – 80 l/min (15.84 – 21.12 gpm)
- Pressure: 230 bar (3336 psi)
- Diesel engine speed ≈ 800 rpm

**Determine pump speed**

As example a PTO with a Gear Ratio of 1:1.54.

The pump speed will be:

- $800 \times 1.54 \approx 1200$  rpm

**Select a suitable pump size**

Use diagram 1 and select a pump that will provide 60 – 80 l/min at 1200 rpm.

Follow line 'a' (1200 rpm) until it crosses line 'b' (70 l/min).

- F1-61 is a suitable choice

**Required input torque**

Make sure the PTO and the gear-box tolerates the pump torque. Use diagram 2 to obtain the required pump torque.

Follow a line from 'c' (230 bar) until it crosses the F1-61 line (the selected pump).

- Read 220 Nm (at 'd')

**NOTE:** A rule-of-thumb is to select the highest PTO ratio and the smallest pump size that meets the crane specification without exceeding the pump speed, pressure, and power limitations.

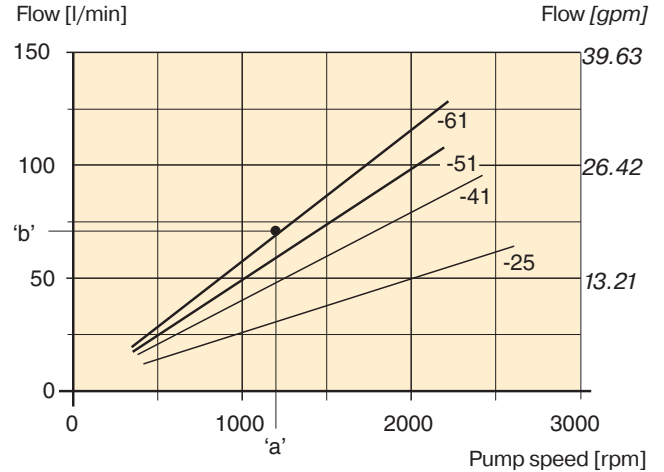

Diagram 1.

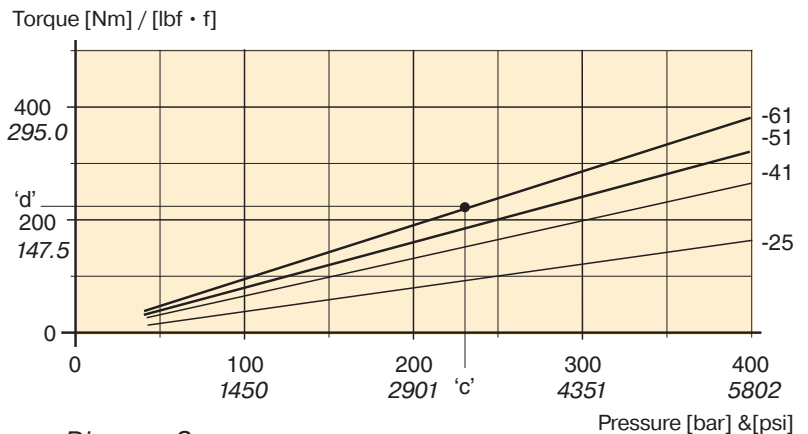

Diagram 2.

**Line selection  
all pumps**

Line type	Flow velocity [m/s] [feet/s]
Inlet (suction)	max 1.0 / 3.28
Outlet (pressure)	max 5.0 / 16.40

Flow rate [l/min] gpm	Flow velocity [m/s] [feet/s] at selected line sizes [mm/inches]							Inlet (suction) line
	19 / 3/4"	25 / 1"	32 / 1 1/4"	38 / 1 1/2"	51 / 2"	64 / 2 1/2"	75 / 3"	
25/6.60	1.5 / 4.92	0.8 / 2.62	0.5 / 1.64	0.4 / 1.31	0.2 / 0.66	0.1 / 0.33	0.1 / 0.33	
50/13.21	2.9 / 9.51	1.7 / 5.58	1.0 / 3.28	0.7 / 2.30	0.4 / 1.31	0.3 / 0.98	0.2 / 0.66	
75/19.81	4.4 / 14.44	2.5 / 8.20	1.6 / 5.25	1.1 / 3.61	0.6 / 1.97	0.4 / 1.31	0.3 / 0.98	
100/26.42	5.9 / 19.36	3.4 / 11.15	2.1 / 6.89	1.5 / 4.92	0.8 / 2.62	0.5 / 1.64	0.4 / 1.31	
150/39.63	8.8 / 28.87	5.1 / 16.73	3.1 / 10.17	2.2 / 7.22	1.3 / 4.27	0.8 / 2.62	0.5 / 1.64	
200/52.83	-	-	4.1 / 13.45	2.9 / 9.51	1.6 / 5.25	1.1 / 3.61	0.7 / 2.30	
250/66.04	-	-	5.3 / 17.39	3.7 / 12.14	2.1 / 6.89	1.3 / 4.27	0.9 / 2.95	

Table 1. Outlet (pressure) line



In order to obtain sufficient inlet (suction) pressure to the pump, low noise level and low heat generation, flow speeds shown in table 2, right, should not be exceeded.

From table 1 (page 13), select the smallest line dimension that meets the flow speed recommendation; example:

- At 100 l/min 26.42 gpm, a 50 mm 2" suction line and a 25 mm 1" pressure line is needed.

**NOTE:** Long inlet (suction) lines, low inlet pressure (caused by e.g. a reservoir positioned below the pump) and/or low temperatures may require larger line dimensions.

Alternatively, the pump speed will have to be lowered to avoid pump cavitation (which may cause noise, deteriorating performance and pump damage).

Line type	Flow velocity [m/s] [feet/s]
Inlet (suction)	max 1.0 / 3.28
Outlet (pressure)	max 5.0 / 16.40

Table 2.

**Nomogram**

Flow – Line dimension – Flow velocity

Example 1  
 Pressure line  
 Q = 65 l/min  
 17.17 gpm  
 d = 3/4"  
 v = 3.8 m/s  
 12.47 feet/s

Example 2  
 Suction line  
 Q = 50 l/min  
 13.21 gpm  
 v = 0.8 m/s  
 2.62 foot/s  
 d = 1 1/2"

1gpm=3.785 l/min  
 1 l/min=0.264 gpm  
 1 foot/s=0.305 m/s  
 1 m/s=3.281 feet/s  
 1psi=0.0689 bar  
 1 bar=14.504 psi

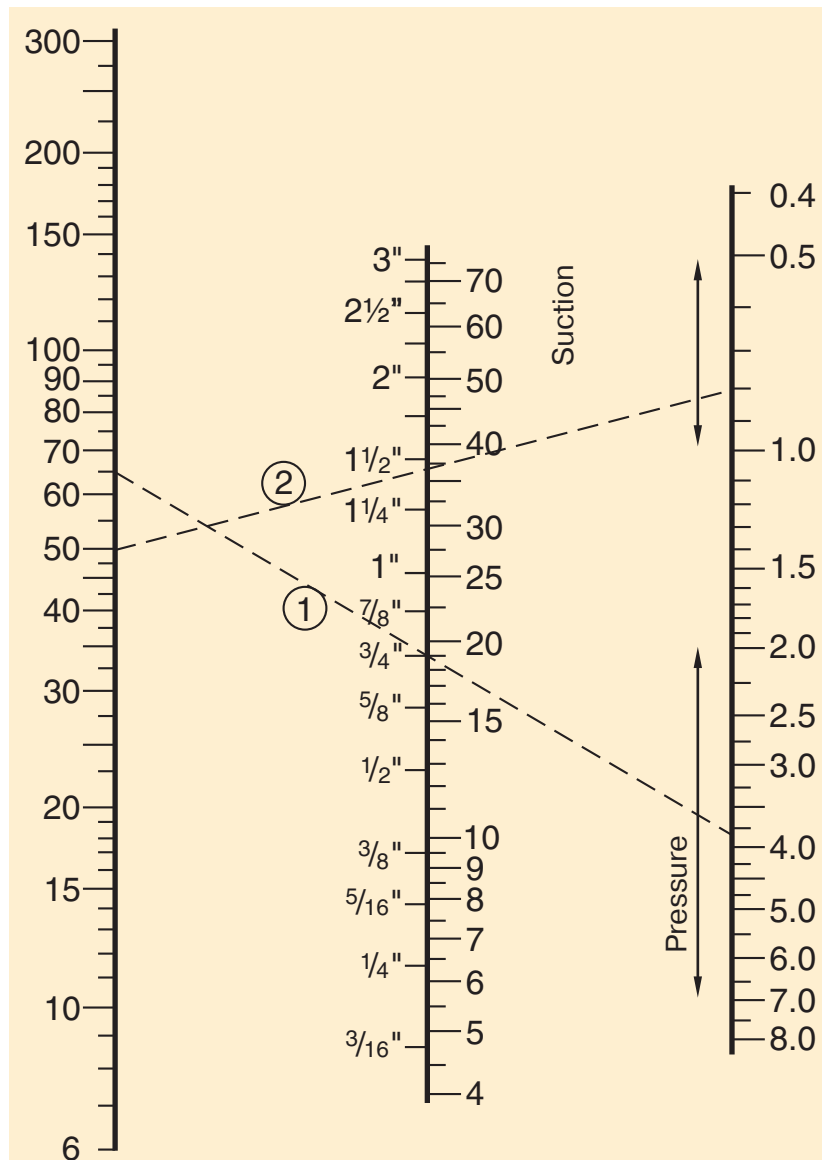

Table 3.

Q = Flow [l/min]

d = internal line diameter [Ø mm]

v = Flow velocity [m/s]

**Suction fittings for series F1, VP1-095, -110 and -130**

**'Straight' suction fittings for F1, VP1-095/-110/-130**

Ordering no.	A mm/inch	B mm/inch	C dia. mm (in.)
378 0635 <sup>1)</sup>	0	85 / 3.35	38 (1 1/2")
378 0636 <sup>2)</sup>	17 / 0.67	136 / 5.35	50 (2")
378 0637 <sup>3)</sup>	25 / 0.98	145 / 5.71	63 (2 1/2")
378 3523 <sup>3)</sup>	32 / 1.26	174 / 6.85	75 (3")

**45° suction fittings for F1, VP1-095/-110/-130**

Ordering no.	A mm/inch	B mm/inch	C dia. mm (in.)
378 1234 <sup>1)</sup>	60 / 2.36	104 / 4.09	32 (1 1/4")
378 0633 <sup>1)</sup>	60 / 2.36	104 / 4.09	38 (1 1/2")
378 0364 <sup>2)</sup>	67 / 2.64	110 / 4.33	50 (2")
378 0634 <sup>3)</sup>	75 / 2.95	117 / 4.61	63 (2 1/2")
378 3367 <sup>3)</sup>	95 / 3.74	138 / 5.43	75 (3")
378 1062	67 / 2.64	110 / 4.33	40 (1.57)
378 0975	67 / 2.64	110 / 4.33	45 (1.77)

**90° suction fittings for F1, VP1-095/-110/-130**

Ordering no.	A mm/inch	B mm/inch	C dia. mm (in.)
378 0978 <sup>1)</sup>	126 / 4.96	83 / 3.27	38 (1 1/2")
378 0979 <sup>2)</sup>	135 / 5.31	83 / 3.27	50 (2")
378 1980 <sup>3)</sup>	147 / 5.79	83 / 3.27	63 (2 1/2")
378 0976	135 / 5.31	83 / 3.27	45 (1.77)
378 8690 <sup>3)</sup>	185 / 7.28	83 / 3.27	75 (3")

**145° suction fitting for F1, VP1-095/-110/-130**

Ordering no.	A mm/inch	B mm/inch	C dia. mm (in.)
378 1867	165 / 6.50	73 / 2.87	50 (2")

- 1) Recommended for size F1-25.
- 2) Recommended for size F1-41,-51,-61.
- 3) (3 clamps and 3 screws)

**Spare parts**

Additional Hold-down-clamp kit consists of:  
hold-down-clamp cap screw and O-ring  
Ordering no. 378 1321

Additional Hold-down-clamp kit for mounting on BPV  
Ordering no. 378 2439

**NOTE:** A suction fitting *must be ordered separately* (not included with the pump). To choose the correct dimension of suction connection, see chapter 3.

A 'suction fitting' consists of a straight, 45°, 90° or 135° suction fitting, clamps, cap screws and O-ring.

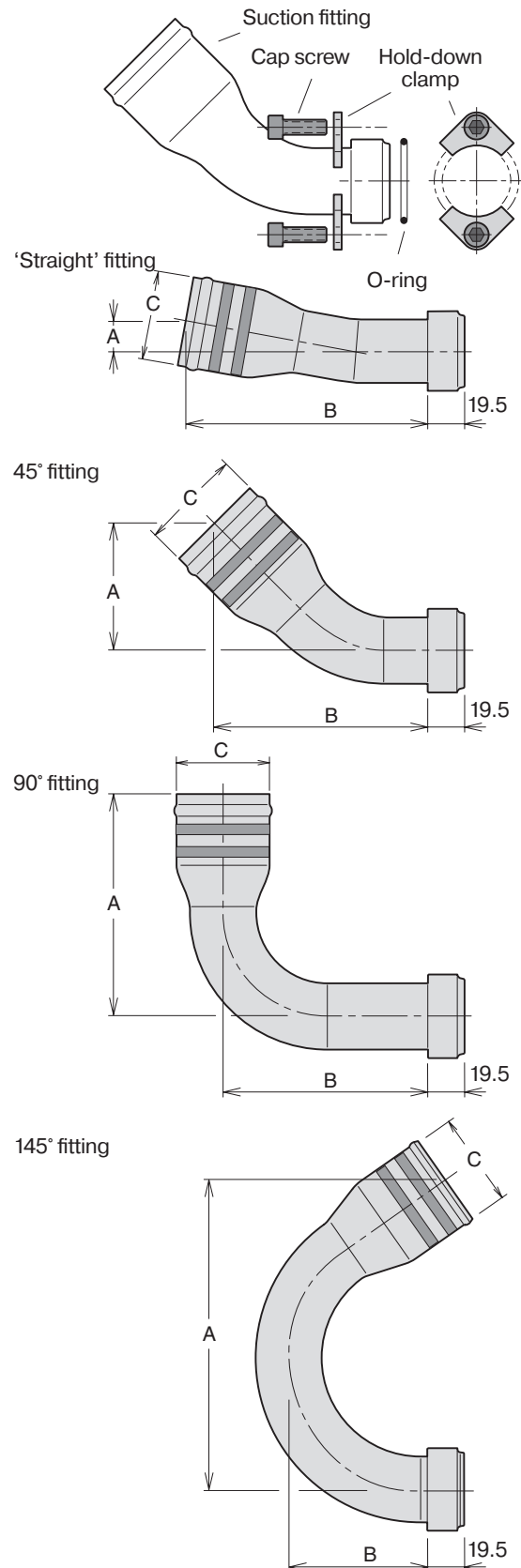

**Installation and start-up for F1**

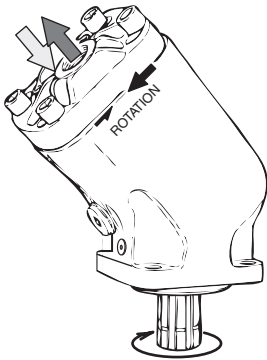

*Left hand (L.H.; counter clockwise) rotating pump.*

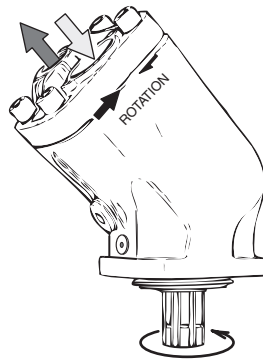

*Right hand (R.H.; clockwise) rotating pump.*

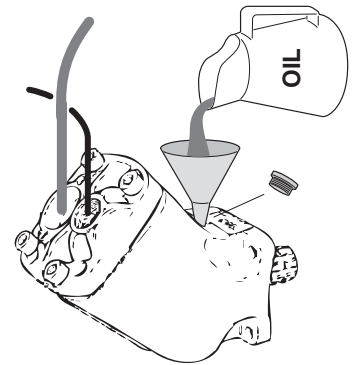

*Before start-up, the housing must be filled with hydraulic fluid.*

**Direction of rotation**

The pictures above show direction of flow vs. shaft rotation.

The direction of rotation can be changed (i.e. from right hand to left hand) by turning the end cap.

Remove the four cap screws and turn the end cap about half a turn while making sure it stays in contact with the barrel housing.

Re-fit the cap screws and torque to 59 – 74 lbf ft (80 – 100 Nm).

**Installation**

Make sure max torque and bending moment (due to the weight of the pump) of the utilised PTO are not exceeded. (The approx. center of gravity of the various pump sizes are shown in the installation drawings).

**NOTE:**

In order to obtain the longest bearing life, the pump should be installed according to the information shown on page 20 "Pump bearing life".

**Fluid viscosity**

Recommended viscosity:  
 20 to 30 mm<sup>2</sup>/s (cSt).

Operating viscosity limits:

- Min 10 mm<sup>2</sup>/s; max 400 mm<sup>2</sup>/s.
- At start-up, max 4000 mm<sup>2</sup>/s.

**Fluids**

The fixed displacement pumps data shown in the specifications for each pump in chapter 1 and 2 are valid when operating on high quality, mineral based hydraulic oil.

Type HLP (according to DIN 51524) hydraulic oil is suitable as well as biologically degradable fluids like natural and synthetic esters and polyalphaolefins.

The utilised hydraulic fluid shall meet one of the following Swedish standards:

- SS 15 54 34
  - SMR Hydraulic Oil Standard 1996-2.
- Contact Parker Hannifin for further information.

**NOTE:**

- ATF (automatic transmission fluid) and API type CD engine oils may also be useable.
- Seals are made of nitrile rubber; make sure the utilised fluid is compatible with this material.

**Fluid temperature**

Main circuit: Max 75 °C, 167 °F.

**NOTE:**

- The suction port should always be above the pressure port when the pump is installed above the reservoir oil level.
- During operation, the pump must be filled with oil to at least 50 %.

**Drain line**

Fixed displacement pumps don't need an external drain line as they are internally drained.

When the pump is mounted in a Engine-PTO we recommend a drain line from the bypass valve directly to oil tank.

**Filtration**

Filtration should follow ISO standard 4406, code 20/18/13.

To obtain the longest life of fixed displacement pumps, we recommend an oil cleanliness of 10 µm (absolute).

**Start-up**

Make sure the entire hydraulic system is clean before filling it with a recommended hydraulic fluid.

In particular, make sure the pump is filled (to at least 50 %) as the internal leakage does not provide sufficient lubrication at start-up.

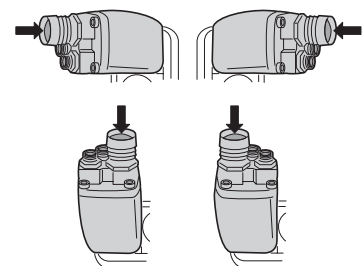

**Pump bearing life**

Bearing life is dependent on how the pump is installed on the PTO as shown in the illustrations below.

A pump mounted according to fig. 1 gives the lowest bearing life; the highest is obtained when installed according to fig. 3.

Parker Hannifin will assist in determining bearing life in a particular application.

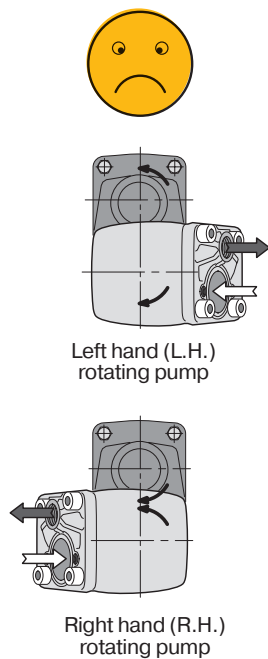

Fig. 1.

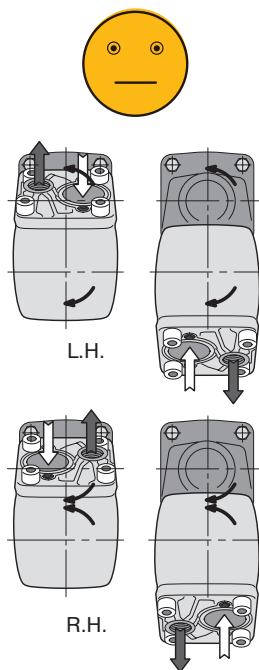

Fig. 2.

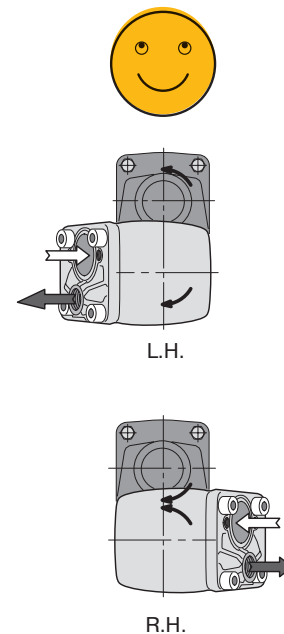

Fig. 3.

## Installation and start-up for VP1

### Direction of rotation

The basic VP1 pump is uni-directional; there is a left hand and a right hand version (indicated by the arrow on the side of the VP1 pump (fig. 4 and 5).

Consequently, the required direction of rotation must be stated when ordering the pump.

### Installation

The VP1 can be installed (close-coupled) directly on a PTO.

Before start-up, the pump must be filled with hydraulic fluid and purged. Utilise the uppermost purge plug (refer to the installation drawing on page 12, chapter 2).

Figure 6 (page 19) shows two ways of installing a gear on the VP1 shaft. On a non-geared or a geared PTO with support bearings, the pump shaft is usually installed directly in the internally splined PTO output shaft.

Make sure max torque and bending moment (due to the weight of the pump) of the utilised PTO are not exceeded. (The approx. center of gravity of the various pump sizes are shown in the installation drawings).

### Hydraulic fluids

The VP1 data shown in the specifications on page 10 are valid when operating on a high quality, mineral based fluid.

Hydraulic fluids type HLP (DIN 51524), ATF (automatic transmission fluids), and API type CD engine oils are suitable.

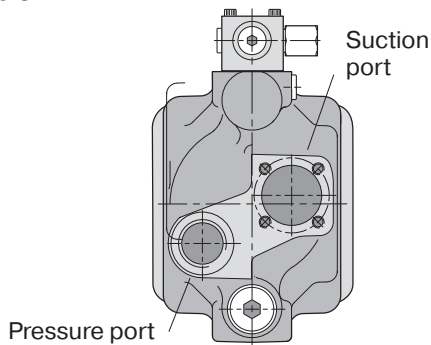

Fig. 4. Left hand rotating pump.

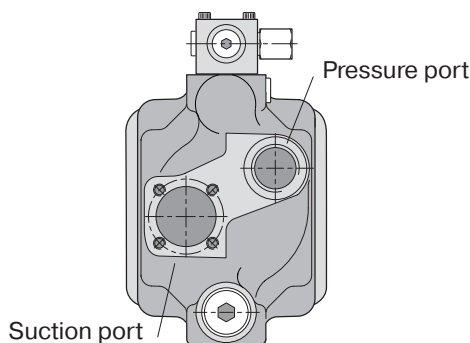

Fig. 5. Right hand rotating pump.

### Fluid temperature

Main circuit: Max 75 °C 167 °F.

### Viscosity

Recommended viscosity:	20 to 30 mm <sup>2</sup> /s (cSt).
Operating viscosity limits:	10 to 400 mm <sup>2</sup> /s.
At start-up:	Max 1000 mm <sup>2</sup> /s.

### Filtration

To obtain long VP1 life, we recommend a filtration level of:

- 25 µm (absolute) in clean environment or at low pressures.
- 10 µm (absolute) in contaminated environment or at high pressures.

Filtration should meet ISO standard 4406: code 20/18/13.

### Drain line

The LS valve *requires a separate drain line*; it should be routed directly to the reservoir (refer to fig. 8).

### Start-up

Make sure the entire hydraulic system is clean before filling it with a recommended fluid.

In addition, the VP1 pump must be purged to remove any entrapped air in the pump housing; utilise the uppermost purge port (fig. 8).

### IMPORTANT

As shown in fig. 8, the pump inlet must always be below the lowest reservoir oil level.

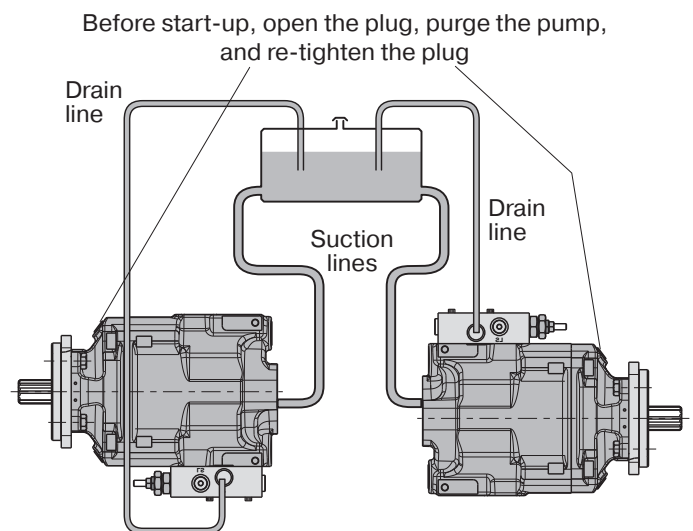

Fig. 8. VP1 should be installed below the reservoir fluid level.

*Purging should be performed when the pump is connected to the reservoir and the system is filled with fluid.*





# Parker Worldwide

## Europe, Middle East, Africa

**AE – United Arab Emirates,**  
Dubai

Tel: +971 4 8127100

**BE/NL/LU – Benelux,**  
Hendrik Ido Ambacht  
Tel: +31 (0)541 585 000

**BY – Belarus,** Minsk  
Tel: +48 (0)22 573 24 00

**CH – Switzerland,** Etoy  
Tel: +41 (0)21 821 87 00

**CZ – Czech Republic,**  
Prague  
Tel: +420 284 083 111

**DE – Germany,** Kaarst  
Tel: +49 (0)2131 4016 0

**DK – Denmark,** Ballerup  
Tel: +45 43 56 04 00

**ES – Spain,** Madrid  
Tel: +34 902 330 001

**FI – Finland,** Vantaa  
Tel: +358 (0)20 753 2500

**FR – France,** Contamine s/Arve  
Tel: +33 (0)4 50 25 80 25

**HU – Hungary,** Budaörs  
Tel: +36 23 885 470

**IE – Ireland,** Dublin  
Tel: +353 (0)1 466 6370

**IL – Israel**  
Tel: +39 02 45 19 21

**IT – Italy,** Corsico (MI)  
Tel: +39 02 45 19 21

**NO – Norway,** Asker  
Tel: +47 66 75 34 00

**PL – Poland,** Warsaw  
Tel: +48 (0)22 573 24 00

**PT – Portugal**  
Tel: +351 22 999 7360

**RO – Romania,** Bucharest  
Tel: +40 21 252 1382

**RU – Russia,** Moscow  
Tel: +7 495 645-2156

**SE – Sweden,** Borås  
Tel: +46 (0)8 59 79 50 00

**SL – Slovenia,** Novo Mesto  
Tel: +386 7 337 6650

**TR – Turkey,** Istanbul  
Tel: +90 216 4997081

**UK – United Kingdom,** Warwick  
Tel: +44 (0)1926 317 878

**ZA – South Africa,**  
Kempton Park  
Tel: +27 (0)11 961 0700

## North America

**CA – Canada,** Milton, Ontario  
Tel: +1 905 693 3000

**US – USA,** Cleveland  
Tel: +1 216 896 3000

## Asia Pacific

**AU – Australia,** Castle Hill  
Tel: +61 (0)2-9634 7777

**CN – China,** Shanghai  
Tel: +86 21 2899 5000

**HK – Hong Kong**  
Tel: +852 2428 8008

**IN – India,** Mumbai  
Tel: +91 22 6513 7081-85

**JP – Japan,** Tokyo  
Tel: +81 (0)3 6408 3901

**KR – South Korea,** Seoul  
Tel: +82 2 559 0400

**MY – Malaysia,** Shah Alam  
Tel: +60 3 7849 0800

**NZ – New Zealand,**  
Mt Wellington  
Tel: +64 9 574 1744

**SG – Singapore**  
Tel: +65 6887 6300

**TH – Thailand,** Bangkok  
Tel: +662 186 7000

**TW – Taiwan,** Taipei  
Tel: +886 2 2298 8987

## South America

**AR – Argentina,** Buenos Aires  
Tel: +54 3327 44 4129

**BR – Brazil,**  
Sao Jose dos Campos  
Tel: +55 080 0727 5374

**CL – Chile,** Santiago  
Tel: +56 22 303 9640

**MX – Mexico,** Toluca  
Tel: +52 72 2275 4200

### European Product Information Centre

Free phone: 00 800 27 27 5374

(from AT, BE, CH, CZ, DE, DK, EE, ES, FI,  
FR, IE, IL, IS, IT, LU, MT, NL, NO, PL, PT,  
RU, SE, SK, UK, ZA)



### Parker Hannifin Ltd.

Tachbrook Park Drive  
Tachbrook Park,  
Warwick, CV34 6TU  
United Kingdom  
Tel.: +44 (0) 1926 317 878  
[www.parker.com](http://www.parker.com)